

NESTRA

Next generation Space systems Technology Research Association

MIPS

Miniature Ion Propulsion System

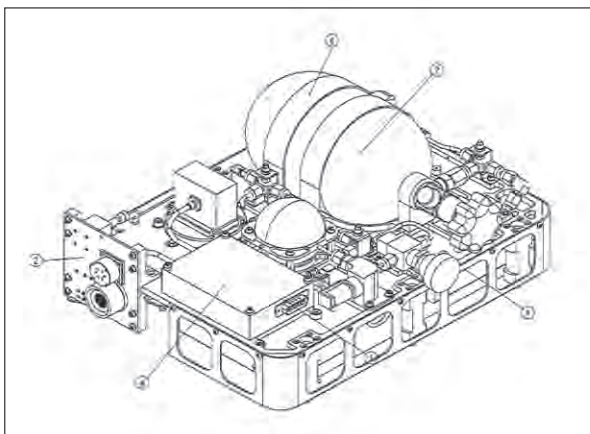
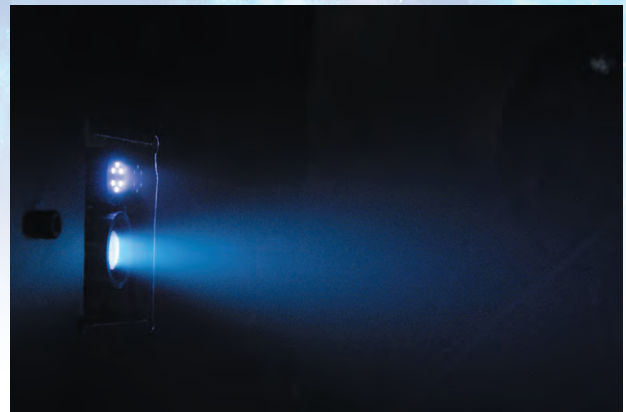
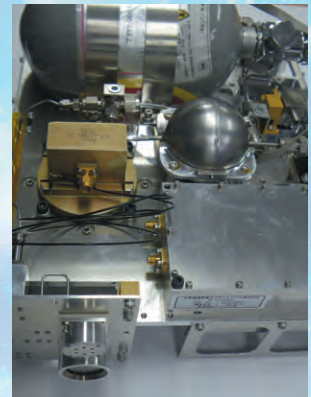
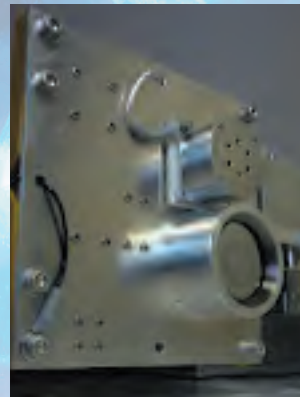
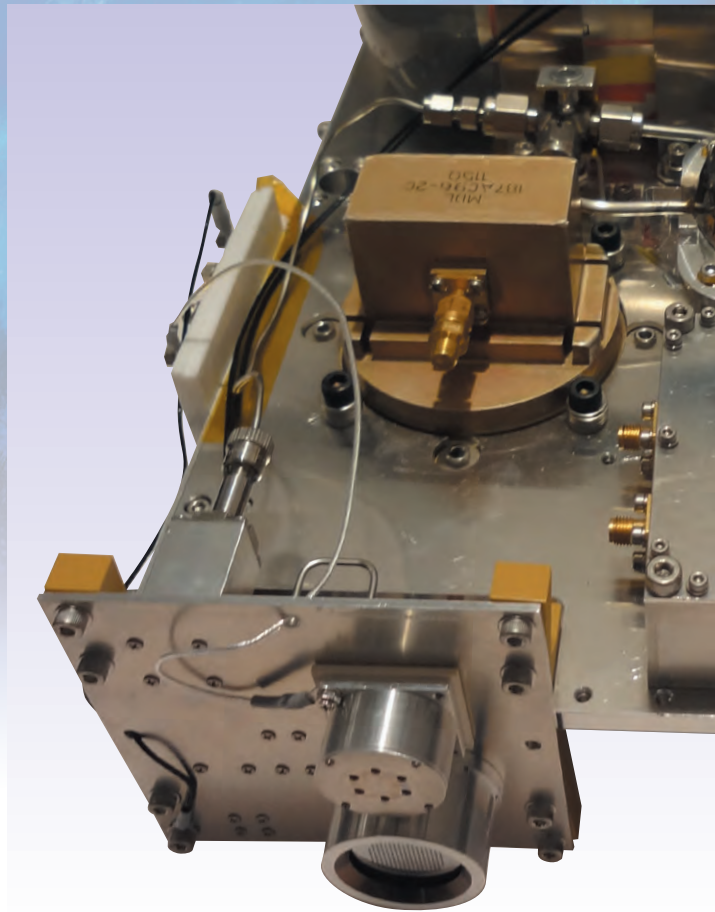

SPECIFICATIONS

Total Volume	39×28×16cm
Total Mass	6kg (incl.1kg Xe)
Power Consumption	30 W
Thrust Level	250 μ N
Specific Impulse	1200 s
Total Impulse	12000Ns
Total Velocity	240 m/s (50kg S/C)
Ion Thruster Unit	Ion Source + Neutralizer

CONTACT

NESTRA
Next generation Space systems Technology Research Association

Next generation Space systems Technology Research Association

2-22-21 Hongo MK Building No202,
Nishikata, Bunkyo-ku, Tokyo 113-0024 JAPAN
Tel: +81-3-5842-2677 Fax: +81-3-5842-2678

<http://www.nestra.jp>

All right are reserved. Subject to change without prior notice.

NESTRA

Next generation Space systems Technology Research Association

FOG-IRU N-FOG 5

Fiber Optical Gyro - Inertial Reference Unit

Run Bias Stability $<1.5^\circ/h$ (1σ)
Allan Variance $0.15^\circ/h$ (1σ) @100sec



FEATURE

- Superior Bias stability
- Excellent cost/performance
- Integrated FOG Drive Electronics
- 2013 Flight

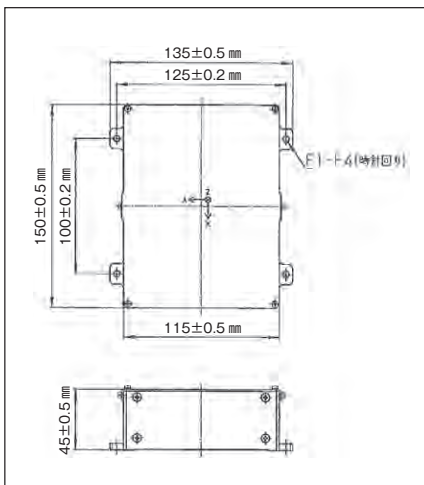

SPECIFICATIONS

Performance

Max Input Rate Range	$\pm 5^\circ / \text{sec}$
Scale Factor	$400 \text{mV}^\circ / \text{sec}$
Scale Factor Stability	0.1%FS
Bias Stability (ON-OFF)	$5^\circ / \text{h}$ (Max Spread)
Bias stability (Run)	$<5^\circ / \text{h}$ (1σ)
Allan Variance	$<1^\circ / \text{h}$ (1σ) @1sec

Mechanical

Mass	$<1 \text{kg}$
Dimension (without flange)	$L155 \text{mm} \times B120 \text{mm} \times H50 \text{mm}$
Miss Alignment	$<0.1^\circ$

Electrical

Voltage	$+22 \text{V} \sim +36 \text{V}$
Power Consumption	$<3.2 \text{W}$

Data Interface

RS422

Environmental Condition

Operating Temperature Range	$-10^\circ \text{C} \sim +50^\circ \text{C}$
Non Operating Temperature Range	$-20^\circ \text{C} \sim +60^\circ \text{C}$
Random Vibration	17.6 Grms
Total Dose	$>15 \text{Krad}$

General

+15V Voltage available	(Power Consumption $<3.5 \text{W}$)
Polarity	Light hand rule
Design Life	>5 years

CONTACT

NESTRA
Next generation Space systems Technology Research Association

Next generation Space systems Technology Research Association
2-22-21 Hongo MK Building No202,
Nishikata, Bunkyo-ku, Tokyo 113-0024 JAPAN
Tel: +81-3-5842-2677 Fax: +81-3-5842-2678

<http://www.nestra.jp>